



**TETON**

Natural Reliability™



**XA SERIES**

Teton Aeration Pump

**INSTRUCTION MANUAL**

# TETON AERATION PUMP

## XAP20-XAP160

VERSION May 2020

[www.tetonus.com](http://www.tetonus.com)

800.752.0399

[info@tetonus.com](mailto:info@tetonus.com)

**WELCOME TO THE WORLD OF TETON,  
NATURAL RELIABILITY!**

You Made The Right Choice Investing In This Quality Product. Thank You And Enjoy.

**BEFORE USING THIS PRODUCT, PLEASE READ  
THESE INSTRUCTIONS CAREFULLY AND  
FAMILIARIZE YOURSELF WITH THE UNIT. PLEASE  
KEEP THESE INSTRUCTIONS IN A SAFE PLACE  
FOR FUTURE REFERENCE.**

### TECHNICAL SPECIFICATIONS

MODEL NO.	XAP20	XAP40	XAP60	XAP80	XAP120	XAP160
<b>AIR FLOW RATE</b>	25 LPM @ 1.75 psi	40 LPM @ 1.75 psi	60 LPM @ 1.75 psi	80 LPM @ 2psi	150 LPM @ 2psi	180 LPM @ 2psi
<b>MAXIMUM PRESSURE</b>	4.5psi/ 0.32 kg/cm <sup>2</sup>	5.5psi/ 0.39 kg/cm <sup>2</sup>	5.6psi/ 0.40 kg/cm <sup>2</sup>	7psi/ .050 kg/cm <sup>2</sup>	7psi/ .050 kg/cm <sup>2</sup>	7psi/ .050 kg/cm <sup>2</sup>
<b>POWER CONSUMPTION</b>	20 W	37 W	55 W	80 W	120 W	155 W
<b>RATED VOLTAGE</b>	115V- AC	115V- AC	115V- AC	115V- AC	115V- AC	115V- AC
<b>RATED FREQUENCY</b>	60HZ	60HZ	60HZ	60HZ	60HZ	60HZ
<b>CABLE LENGTH</b>	16 ft/5 m	16 ft/5 m	16 ft/5 m	16 ft/5 m	16 ft/5 m	16 ft/5 m
<b>OUTLET DIAMETER</b>	5/8 "/17mm	5/8 "/17mm	5/8 "/17mm	5/8 "/17mm	1"/25 mm	1"/ 25mm
<b>UNIT WEIGHT</b>	4 lb/1.8 kg	9.2 lb/4.2 kg	10.4 lb/4.7 kg	10.8 lb/.9 kg	16.3lb/7.4kg	16.8lb/7.6kg
<b>UNIT SIZE L x W x H</b>	195x150x160mm 7-5/8"x6"x6-3/8"	250x185x 190mm/ 9-7/8"x 7"x7"	250x185x 190mm/ 9-7/8"x 7"x7"	250x185x 190mm/ 9-7/8"x7"x7"	300x230x 230mm/ 11" x 9" x 9"	300x230x 230mm/ 11" x 9" x 9"

## DESIGN HIGHLIGHTS:

- Weatherproof casing design for outdoor use.
- Quiet operation - Outer industrial plastic casing and air baffle, and extra buffer chamber on outlet for exceptional low noise rating.
- Dual Rubber mounting system for vibration absorption.
- Large air flow and strong air pressure for deeper pond water penetration.
- No oil lubrication needed.
- Easy maintenance - Replaceable internal rubber diaphragms.
- Continuous rated - Designed to operate 24/7.

## BENEFITS INCLUDE

The Teton Aeration Pump has been manufactured with advanced technology to provide you with the best quality aeration for your pond, aquarium or aquaculture application. Teton Aeration Pumps are suitable for many different applications including winter time ice reduction on pond surfaces.

## IMPORTANT SAFEGUARDS



Please read the operating instructions and familiarize yourself with the equipment before placing it in service. Correct and safe use of the system requires strict compliance with these safety instructions. For safety reasons, persons less than 16 years of age or persons that are not familiar with these instructions, should not use this equipment.

- The equipment should be placed out of reach of children. Damage to the equipment or unmerited operation can potentially bring dangers to the surrounding precincts. If there is any damage of the equipment, it must not to be used.
- For your own safety, completely disconnect all electrical appliances before any maintenance of equipment is attempted on/in the tank or body of water. Always unplug the air pump from the power supply when not in use. Never pull the cable to disconnect the plug from the power supply: grasp the plug and pull to disconnect. Care should be taken to ensure the power cable is situated to avoid a tripping hazard.
- **Cutting the cable may void your warranty.**
- If required, have a qualified electrician install a weatherproof power supply point in reach or the water-feature (within the cable length of the appliance). For applications within the US or Canada- make sure to plug the pump into an electrical outlet with a (GFCI) Ground Fault Circuit Interrupter.
- To prevent electric shocks, do not attach the plug to the power supply socket with wet hands. On installation, the drip loop method should be used to prevent water from traveling down the cable and onto the plug or into power supply. If the plug does get wet, do not unplug the cable. Immediately disconnect the circuit breaker that supplies power to the power supply point. Unplug and examine the plug and power supply point for the presence of water. If the power point has become wet, you should consult an electrician before using the power point again.
- Do not submerge air pump directly in water. The distance from aeration pump to the water's edge should not be less than 6 ft/1.8 m.
- Do not operate the appliance if any components of the system, such as the power cable, have been damaged. Check appliance and components of the kit for defects regularly.
- Do not install or store the appliance where it will be exposed to extreme hot or cold temperatures. This pump is approved for usage in temperatures ranging from 20°F/5°C to 100°F/40°C. Do not use in ambient temperatures above 100°F/40°C.
- Do not attempt to repair the electrical appliance yourself. Return to an authorized dealer or place of purchase if a fault occurs. Regular maintenance is not considered a repair (e.g. replacing the diaphragms and air filter is required by user).

## PRODUCT SPECIFIC SAFEGUARDS

- The air pump is designed to be used in garden pond or aquarium applications. It is not to be used in any other manner or purpose. Do not use the pump in, or in conjunction with, any chemicals such as a solvent or gasoline or flammable gases. The pump is designed to pump clean atmospheric air only.
- When transporting, do not lift the pump by holding the filter cover: grasp pump by the lower housing to carry.
- Every air pump may eventually “wander” or “creep” due to its own vibration. Avoid this by placing it on an entirely level and flat plane. We recommend securing it with a tie or cable tie to anchor it to a secure surface.
- Teton Aeration Pumps are cooled by air flowing through the inside of the motor body chamber. If the air flow becomes restricted, it will overheat and could cause permanent damage to the electrical components internally. Keep the tubing length to within 30 ft/10 m. In the event that the tubing provided isn't long enough, keep in mind that large tubing size is strongly recommended to deliver adequate flow over longer distances. This reduces friction loss within the tubing itself.
- The air pump air filter needs to be cleaned regularly to prevent the pump becoming clogged with dust, causing the airflow to reduce. In the absence of recommended maintenance, motor burnout is not a warrantable event.
- Never leave the air pump running without sufficient counter pressure (air stones). This may potentially cause the rubber diaphragms to wear or tear prematurely. The overall performance will also be greatly reduced.
- Teton Aeration Pumps are designed to operate at a maximum depth of 6 ft/2m. Exceeding the maximum pressure will increase diaphragm wear.
- As with all air pumps, wear and tear will inevitably occur over time. PondMAX air pump diaphragm assemblies are easy to replace. Only use original Teton parts and accessories for the unit. See the diaphragm replacement instructions with detailed diagrams below.

## INSTALLATION AND MAINTENANCE

The Teton Aeration Pump is designed for oxygen enrichment via air stones and airline.

For your convenience the Teton Aeration Pump includes:

1. Rubber elbow
2. Hose clamps
3. Replacement Air Filter

Install at least 6 ft/2m away from the water's edge to ensure that there is no intake of moisture. Be sure the air pump itself is not submersed in water. Install horizontally above water level. For best results, mount pump in a cool, shaded location.

### Cleaning Air Filter Pad



**WARNING:** Make sure to unplug power prior to performing maintenance on the air pump or any of its accessories. We recommend general maintenance of the unit every 3 months (more or less depending on circumstance).

The air filter under the top filter cap needs to be removed and the dust cleaned to free up the air flow.

Do this as follows:

1. Loosen the Philips screw at the center of the top of the main housing.
2. Gently lift the filter cap to gain access to the filter sponge.
3. Remove dust and debris caught in the air filter pad. (A standard household vacuum cleaner is ideal this.)

Reset the cleaned filter in the recess area.

Carefully replace the filter cap and retighten the Philips screw.

## Changing the Diaphragm

If the air flow on the pump has decreased or if there is a “ticking” sound coming from the unit, the unit must be turned off immediately. This is typically a symptom of the rubber diaphragms wearing out and needing to be replaced. To do this, it is necessary to remove the internal air pump motor from the plastic housing.

1. Remove the 4 rubber legs and screws of the lower housing. (Fig. A)
2. Push a flat-head screwdriver between the exhaust tube and upper housing to pry open.
3. Loosen 4 fixing screws of the casing block and separate the casing block from the diaphragm support block and remove the old diaphragm. (Fig. C)
4. Remove the U-nut from the diaphragm support block. (Fig. B & C)
5. Replace the old diaphragm with the new one.
6. Replace the diaphragm support block and casing block, tightening screws securely.
7. Note that the power cable should fit snugly back in the recess on the edge of the housing. Do not allow it to be pinched.

**NOTE:** If this repair is felt to be too challenging or tools are not available to carry out these steps, please take the unit back to the Authorized Dealer or place of purchase to request assistance.

**FIGURE A**

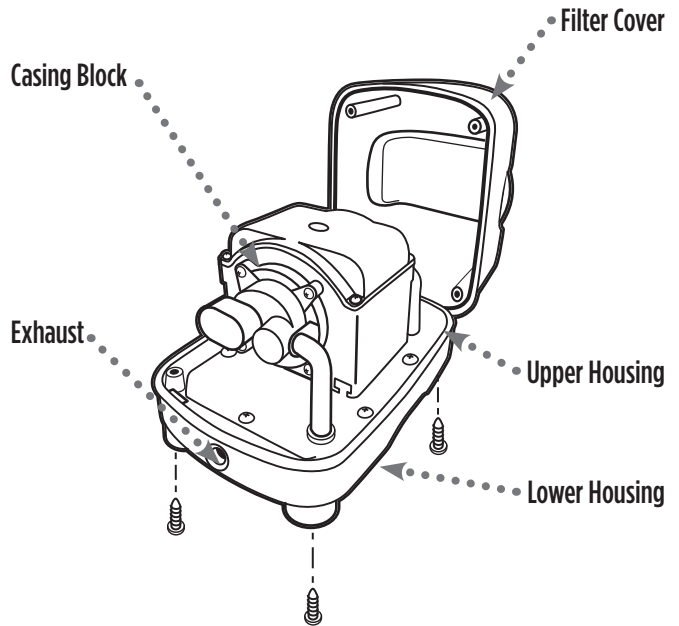

**FIGURE B**

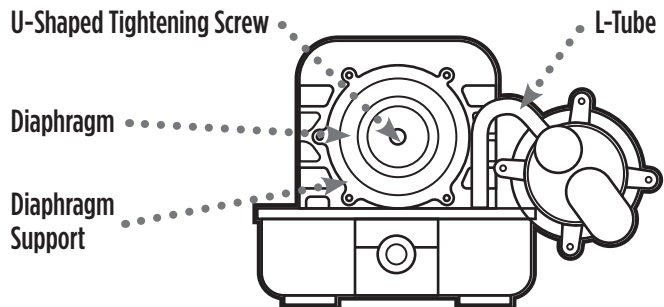

**FIGURE C**

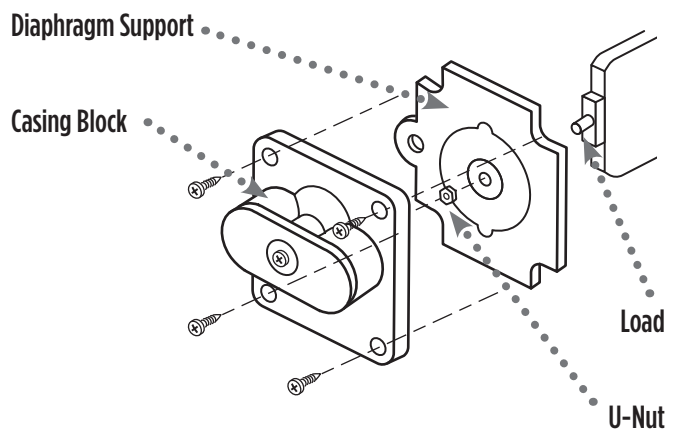

# PARTS BREAKDOWN

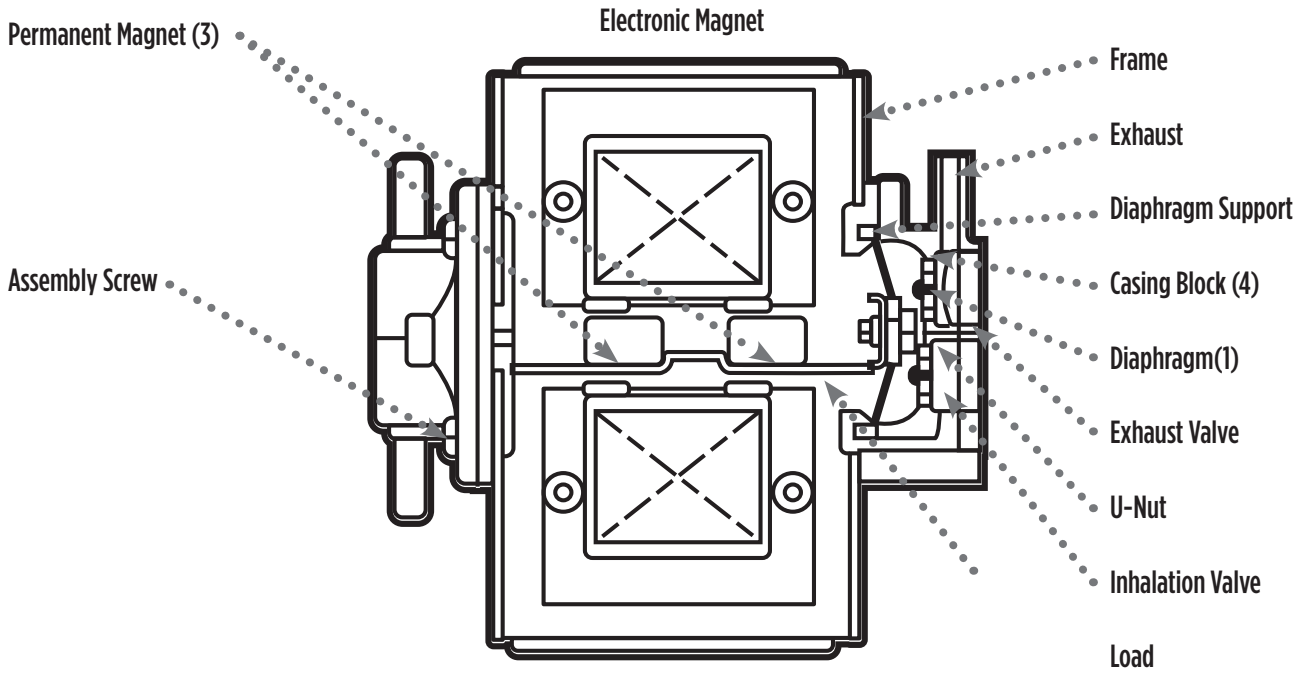

## AVAILABLE REPLACEMENT PARTS

FOR MODEL NO.	XAP20	XAP40	XAP60	XAP80	XAP120	XAP160
<b>Diaphragm (1)</b>	870020	870046	870046	870080	870126	870126
<b>Air Filter</b>	873020	873048	873048	873048	873126	873126
<b>Magnet (3)</b>	871020	871040	871060	871080	871126	871126
<b>Casing Block (4)</b>	872020	872046	872046	872080	872126	872126

## TROUBLESHOOTING

<b>PROBLEM</b>	<b>REASON</b>	<b>SOLUTION</b>
<b>PUMP NOT WORKING</b>	No power	Check that the plug on power cable is connected to power and confirm that power point is working.
	Bad motor	Replace the air pump (if applicable).
	Damaged cable	Inspect the entire length of the air pump cable and look for cuts or damage resulting in exposed copper wire. Replace cable or complete unit.
<b>PUMP WORKING INTERMITTINGLY</b>	Damaged cable	Inspect the entire length of the air pump cable and look for cuts or damage resulting in exposed copper wire. Replace cable or complete unit.
	Short circuit/bad connection	Inspect the entire length of the lighting system cable and look for cuts or damage resulting in exposed copper wire. Replace cable or complete fixture where the damage is.
	Defective lamp	Inspect the lamp socket is not damaged and make sure that the inside of fixture is free of moisture. Replace the lamp.
	Air filter sponge clogged	Disassemble top of pump per these instructions and check the air filter sponge for discoloration, caused by dust or dirt. Using a household style vacuum cleaner, suck debris out of sponge until visibly clean. And reinstall.
	Bad diaphragms	Disassemble pump per these instructions and check the diaphragms for excessive wear and tear or possible tearing. If diaphragm is damaged, go ahead and replace before operating the unit again.
<b>PUMP WORKING WITH MINIMAL AIR FLOW OR MAKING LOUD NOISES</b>	Bad diaphragms	Disassemble pump per these instructions and check the diaphragms for excessive wear and tear or possible tearing. If diaphragm is damaged, go ahead and replace before operating the unit again.
	Air filter sponge clogged	Disassemble top of pump per these instructions and check the air filter sponge for discoloration, caused by dust or dirt. Using a household style vacuum cleaner, suck debris out of sponge until visibly clean. And reinstall.
	Airline is kinked or clogged	Inspect the entire length of the airline tubing for possible kinks or debris inside the clear tubing. Replace tubing if damaged or brittle.

## WARRANTY

- This product is warranted to the initial purchaser to be free of defects in materials and manufacture workmanship at the time of initial purchase and for a period of 2 years after. Some parts are consumable (*e.g. rubber diaphragm assemblies, air filter sponge*) and may need to be replaced as part of ongoing product maintenance and are not covered by this Warranty. In the event this unit malfunctions within 2 years from the date of purchase, the sole obligation of Teton Dynamics (hereinafter referred to as Teton) will be to repair the unit or replace with an equivalent new or factory refurbished unit at Teton's discretion, subject to the following condition:
- The malfunction is proved attributable to a defect in materials or manufacture workmanship, including repairs performed under this warranty. Malfunction for any other reason including but not limited to misuse, negligence, accident, or tampering with parts, incorrect wiring, or improper installation will not be remedied under this warranty.
- Teton specifically does not guarantee chemical compatibility, and expressly does not warrant units from any problems caused by chemical attack or failure due to incompatibility of fluid used near this aeration system.
- All warranty repairs must be performed by Teton or a Teton-authorized company.
- Purchaser must retain the purchase receipt and present it with this certificate as proof of ownership and entitlement to warranty repairs. Unauthorized repairs will not be compensated by Teton, and are not the responsibility of Teton, and if such repairs damage the product, such damages are not remedied under this warranty.
- Purchaser shall bear all onsite labor, shipping, packing and insurance costs and all other costs, excluding in house labor and parts necessary to effectuate repairs under this warranty.
- This warranty is in lieu of all other express warranties which now or hereafter might otherwise arise with respect to this product. Any and all limited warranties, including the warranties of merchantability and fitness for particular purpose, shall have no greater duration than the duration period of the express written warranty applicable to this product, and shall terminate automatically the expiration of such duration period.
- Some states do not allow limitations on how long an implied warranty lasts, so the above limitation may not apply to you. No action shall be brought for breach of any implied or express warranty after one year subsequent to the expiration of the duration period of the express written warranty.
- Incidental and consequential damages caused by malfunction, defect, or otherwise, and with respect to breach of any express or implied warranty, are not the responsibility of Teton, and, to the extent permitted by law, are hereby excluded for property damage, loss of livestock and, to the extent not unconscionable, for personal injury damage. Some states do not allow the exclusion or limitation of incidental or consequential damages, so the above limitation or exclusion may not apply to you.
- This warranty does not apply to any malfunction arising out of any application of this product other than normal use, unless such application is upon request specifically approved in writing by Teton.
- The provisions of this warranty are severable and if any provision shall be deemed invalid, the remaining provisions shall remain in full force and effect.
- Rights under this warranty are not assignable without the express prior consent in writing by Teton and, regardless of the terms of such consent in writing, such assignee shall have no greater rights than his assignor had against Teton.

Please consult your retailer for quality original Teton replacement parts.

Visit [www.tetonus.com](http://www.tetonus.com) for your nearest dealer.



**800.752.0399**  
[info@tetonus.com](mailto:info@tetonus.com)